

Output diagram X-,Y-axes

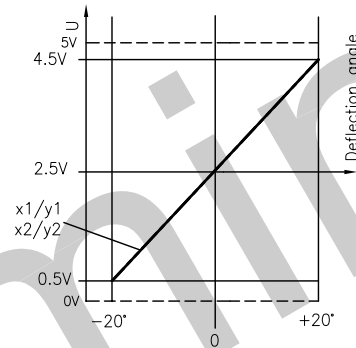

Description	
Joystick Type SK 315-030	
Number of axes	2-axes, x-axis, y-axis both axes are redundant
Operation by	Rubber bellow
Cross guidance	soft
Retaining spring	normal
Connector:	Minitek Shrouded Header 90°, 8-poles
Mating connector:	Minitek IDC Receptacle, 8-poles

Electrical characteristics	
Operating voltage	5 V DC
Sensor	Hall effect technology
Pin	
01	Supply voltage
02	x1 (-x=0.5V, middle=2.5V, +x=4.5V)
03	Ground
04	y1 (-y=0.5V, middle=2.5V, +y=4.5V)
05	y2 (-y=0.5V, middle=2.5V, +y=4.5V)
06	Center tab
07	x2 (-x=0.5V, middle=2.5V, +x=4.5V)
08	do not use

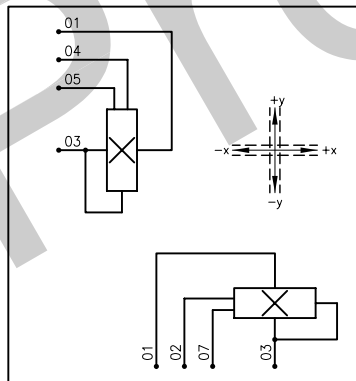

		Oberfläche	Maßstab 1:1	Position	Menge
		Datum	Name	Joystick	
		Bearb. 14.12.12	Kiener M.		
		Gepr.			
		Norm			
		GENGE & THOMA AG <small>01-2543 Lengnau/Blot</small>			Blatt
		Dateiname: E:\DWG\SK 315\LSK315-030.dwg			Bl
Zust.	Änderungen	Datum	Name		