



# SERIES 1683 – PUSHBUTTON SWITCH

DUST AND WATER PROTECTION IP 65 / IP 67



## ADVANTAGE

**High rating**

**Suitable for harsh environmental conditions**

**High level of safety and reliability**

**Numerous versions**

**Attractive, flexible design**

## PRODUCT FEATURES

- Up to 16 (4) A 250 V AC
- Dust and water protection (IP 65 / IP 67)
- Double lifting contact system, tried and tested a million times
- Same size single-pole and two-pole versions, illuminated and non-illuminated versions (LED, glow lamp, bulb) different terminal versions
- Cap available in different colors and with various prints (also customer-specific)

## EXAMPLES OF APPLICATION

- Industrial applications
- Commercial vehicles
- Agricultural machinery
- Construction machinery
- Forklifts
- Municipal vehicles
- Utility vehicles
- Recreational vehicles
- Medical devices
- Laboratory devices
- Small household appliances
- Garden technology
- Cleaning equipment

Rating	
→ Europa	16 (4) A 250 V AC - 1E4 12 (8) A 250 V AC 1E4 10 (8) A 250 V AC - 5E4
→ America	12 A 125 - 250 V AC 1/2 HP
Poles	Single- and two-pole
Switching function	ON / OFF Illuminated and momentary
Protection type	IP 65 and IP 67
Mechanical / electrical life	10E4
Ambient temperature	-20 °C ... +80 °C
Creep resistance (Proof tracking)	250 PTI
Terminal type	Plug, solder and PCB
Actuating force	8 N to 12 N + 1.5 N
Flammability	UL 94 V-2
Approval marks (IEC/UL 61058)	
Suitable for appliances of protection class II	



# SERIES 1683 – PUSHBUTTON SWITCH

DUST AND WATER PROTECTION IP 65 / IP 67

## VARIANTS

Type	Poles	Illumination	Switching function	Terminal type	Optional
1683	1		ON / OFF (SPST)	Quick-connect terminal 2.8	Color, Print, Cable assembly
1683	1		ON / OFF momentary (SPNO)	Quick-connect terminal 4.8	
1684	2		ON / OFF (DPST)	Quick connect terminal 6.3 (vertical and horizontal), PCB terminal	
1684	2		ON / OFF momentary (DPNO)		Color, Print, Cable assembly LED, DC
1686	1	●	ON / OFF (SPST)		
1687	2	●	ON / OFF (DPST)		

## CUT-OUT AND SWITCHING POSITIONS

Recommended cut-out (snap fastening)		
Wall thickness	Length of cut-out	Width of cut-out
1 – 2 mm	19.8 mm <sup>-0.1</sup>	12.9 mm <sup>±0.1</sup>

Switching positions	h
OFF	28
ON	25
Block	23.8

## DRAWINGS

(Dimensions in mm)

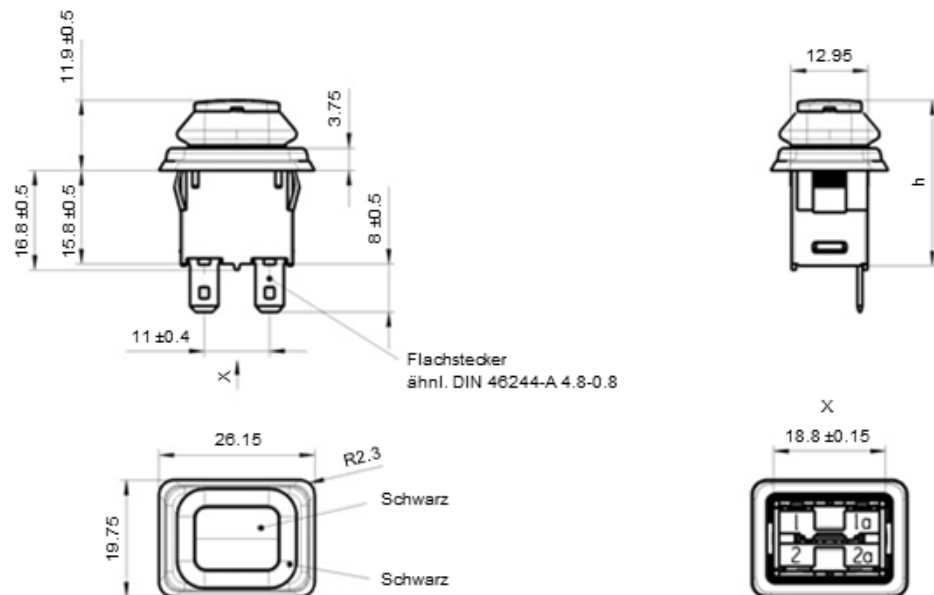

**MARQUARDT**