

OS-552N

FW2

Pitch (terminal to terminal) : 10.16mm

Ordering lot : 100pcs./Unit

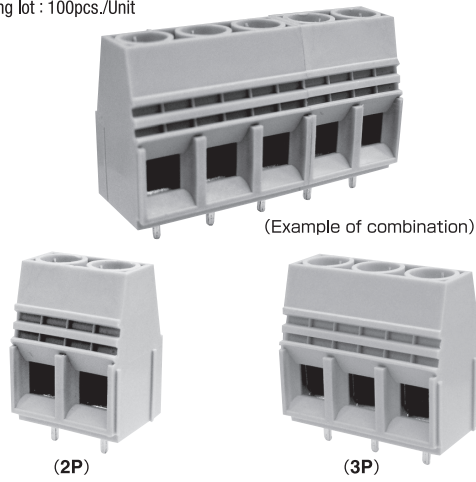

(Example of combination)

Number of terminals : Number of poles required
[combination of 2P and 3P]

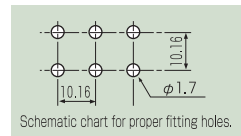
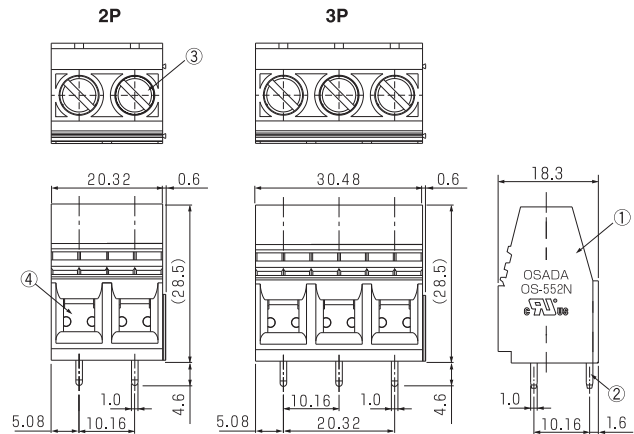

Specifications

Electrical Rating	300V, 65A
Insulation Resistance	DC500V, 1000MΩ
Withstanding Voltage	AC2500V
Cable Range	AWG18~6
Storage Temperature Rating	-40°C~+80°C
Usage Temperature Rating	-40°C~+80°C

Composition

No.	Part Name	Materials	Flame Class	Treatment	Remarks
①	Base	PA66	94V-0		Black
②	Terminal	Brass		Sn	
③	Screw	Steel		Cr ³⁺ Zn	⊕ Screw
④	Contact	Brass		Ni	