

# OK-080

UL (FW2)

PAT

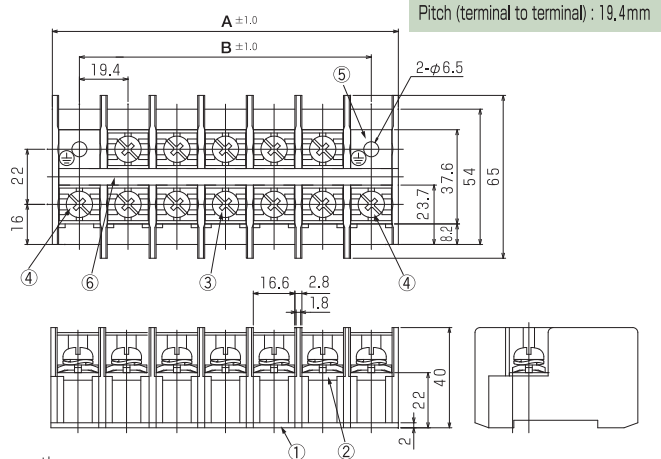
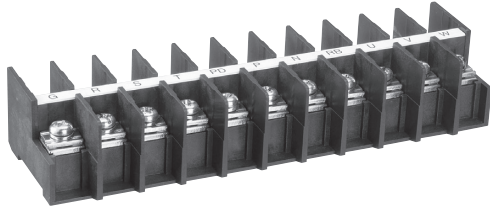

※Marking Strip (Optional)

※Do not use the screw for the earth except the purpose as the earth.

## Specifications

Electrical Rating	850V, 110A (AWG3), 90A (AWG4), 70A (AWG6)
Insulation Resistance	DC1000V, 1000MΩ
Withstanding Voltage	AC2500V
Storage Temperature Rating	-40°C~+90°C
Usage Temperature Rating	-40°C~+90°C

## Composition (2P-8P)

No.	Part Name	Materials	Flame Class	Treatment	Remarks
①	Base	PBT	94V-0		Black
②	Terminal	Brass		Ni	
③	Screw (M6×14L)	Steel		Cr <sup>3+</sup> Zn	F Series
④	Screw for earth	Steel		Cr <sup>3+</sup> Zn	Green
⑤	Mounting Plate	Brass		Ni	
⑥	Marking Strip				Optional

## Measurements List of A & B ( P : Number of terminals )

P	2	3	4	5	6	7	8	9	10
A		99.8	119.2	138.6	158		196.8		235.6
B		77.6	97	116.4	135.8		174.6		213.4