

SUBMINIATURE BASIC SWITCHES

B2
BASIC
SWITCHES

SINGLE BREAK, SNAP-ACTION, COMMERCIAL & MILITARY GRADES, SUBMINIATURE, TWO WIDTHS

Available in two widths, the B2 series can be specified to fit your application exactly.

In addition to being available with integral actuating levers as in the B2-5 series, the B2 series is also available with the A1 series auxiliary lever actuators as shown in the B3 section.

While the B2 series conforms to and is qualified to various military specifications, the same switch can be specified for commercial use at a cost savings.

A choice of turret, quick connect and three lengths of printed circuit board style terminals are available for both the 0.156" and 0.200" wide models.

Whether it be military or commercial applications, OTTO can provide features you select for your application. You can specify the features you require without paying for ones you don't need.

The OTTO B2 subminiature switches conform to and are qualified under MIL-PRF-8805/4, MIL-PRF-8805/106 (high temp -55°C to +205°C) and MIL-PRF-8805/109. Basic switches are designed for miniature spaces where cam or other limit actuators are used on the button. In addition, a full range of toggle, pushbutton and lever actuators are available.

Features:

- Choice of 0.156" & 0.200" wide models
- Up to 7 amps switching
- Sensitive movement differentials
- Low operating forces
- Choice of 8 terminal styles or wire leads
- Long operating life
- Qualified under MIL-PRF-8805/4, MIL-PRF-8805/106 & MIL-PRF-8805/109
- UL recognized & CSA certified
- RoHS/WEEE/Reach compliant



Standard Characteristics/Ratings:

ELECTRICAL RATINGS:

High Level Switch Ratings		
Load	Rating – Sea Level	Rating – 50,000 feet
115VAC, 60Hz silver contacts with gold plate		
Resistive	7A	N/A
Inductive	7A	N/A
Lamp	2A	N/A
28VDC, silver contacts with gold plate		
Resistive	7A	4A
Inductive	4A	2.5A
Lamp	2.5A	2.5A
Low Level Switch Ratings		
28VDC, gold plate contacts		
Resistive	1A	1A
Inductive	0.5A	0.5A
Lamp	N/A	N/A
DWV:	1000Vrms	400Vrms
Electrical Life:	25,000 to 100,000 cycles (dependent on part number)	
Mechanical Life:	50,000 to 250,000 cycles (dependent on part number)	
Seal:	Unsealed	
Operating Temp Range:	-55°C to +85°C, high temp rating -55°C to +205°C	
Operating Force:	5 oz or 6 oz	
Release Force:	1 oz min	
Operate Point:	0.320 +/- 0.015 inches from mounting holes	
Overtravel:	0.004 inches min	
Movement Differential:	0.006 inches max	
Pretravel:	0.020 inches max	
MATERIALS:		
Case:	Thermoset, blue	
Cover:	Thermoplastic, blue	
Button:	Thermoplastic, black	
Terminals:	Brass, gold over nickel	
Contacts:	Stationary: Silver with gold Moveable: Silver or gold	
Terminal Hardware:	None provided	
Optional Wires:	24 AWG blue, red, yellow	
Mounting Hardware:	None provided	

B2 BASICS WITH INTEGRAL LEVERS

SINGLE BREAK, SNAP-ACTION, COMMERCIAL & MILITARY GRADES, SUBMINIATURE, TWO WIDTHS, INTEGRAL LEVERS

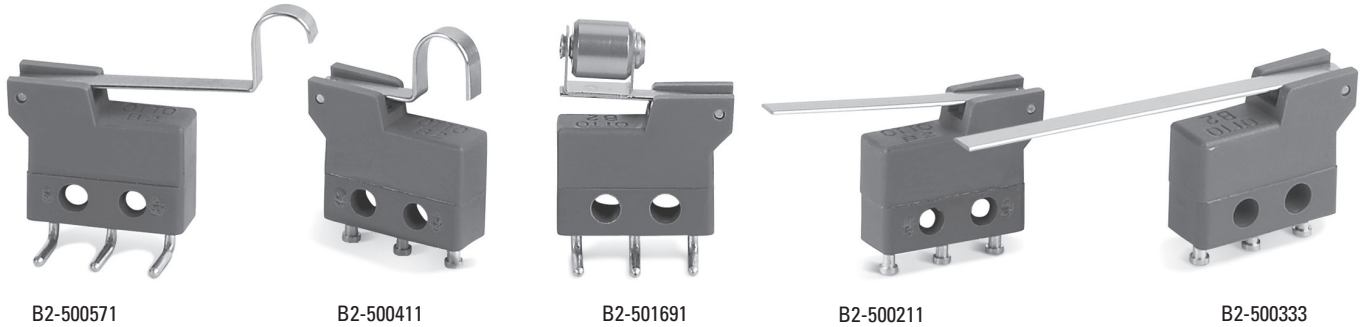

Shown are examples of available lever styles.

B2-5 Integral Lever Basic Switches

B2-5 series basic switches feature integral actuating levers. The lever is built-in so that the switch and actuator are one assembly.

Making the lever actuator an integral part of the basic switch case makes sense and saves money, too. Better precision, no auxiliary parts for you to assemble, and more variety add up to a cost saving proposition.

Lever Style	Catalog Number	STANDARD OPERATIONAL CHARACTERISTICS					
		Operating Force (max ounces)	Release Force (min ounces)	Pretravel (max inches)	Overtravel (min inches)	Move't Differ'l (max inches)	Operating Point (inches)
Short Lever	B2-500111	1.76	0.32	0.065	0.014	0.020	0.330 +/- 0.045
Medium Lever	B2-500211	1.10	0.18	0.115	0.025	0.035	0.330 +/- 0.045
Long Lever	B2-500311	0.71	0.11	0.185	0.046	0.060	0.330 +/- 0.045
Short Formed "U" Lever	B2-500411	2.10	0.39	0.050	0.010	0.015	0.553 +/- 0.035
Long Formed "U" Lever	B2-500511	1.10	0.18	0.105	0.022	0.035	0.572 +/- 0.070
Lever Style with Hole	B2-500611	1.10	0.18	0.115	0.025	0.035	0.330 +/- 0.045
Short "V" Lever	B2-501211	3.00	0.57	0.042	0.010	0.010	0.419 +/- 0.030
Roller Sleeve Sideways	B2-501611	2.29	0.43	0.065	0.008	0.020	0.560 +/- 0.045
Short "L" Lever	B2-501711	3.00	0.57	0.036	0.008	0.009	0.411 +/- 0.028
Short Flat "V" Lever	B2-501811	2.20	0.40	0.049	0.010	0.015	0.421 +/- 0.037
Roller Lever in Line	B2-501911	2.29	0.43	0.070	0.008	0.020	0.559 +/- 0.050
Long Roller Lever in Line	B2-502011	1.00	0.17	0.125	0.020	0.040	0.552 +/- 0.100

B2-5 PART NUMBER CODE

B2-5 **X X X**

Lever Style

- 001. Short Straight
- 002. Medium Straight
- 003. Long Straight
- 004. Short Formed "U"
- 005. Long Formed "U"
- 006. With Hole
- 012. Short "V"
- 016. Roller Sleeve Sideways
- 017. Short "L"
- 018. Short Flat "V"
- 019. Roller Lever in Line
- 020. Long Roller Lever in Line

X

Terminal Style or Wire Length

- 1. Single Solder Turret
- 2. Double Solder Turret
- 3. Quick Connect*
- 4. PC Pin 0.150" lg.
- 5. PC Pin 0.270" lg.
- 6. PC Pin 0.090" lg.
- 7. Right Angle PC Pin
- 9. Right Angle**

X

Contact Material

- 1. Silver/Gold - High Current
- 3. Silver/Gold - Low Current

* Mates with AMP .058" receptacles

** Opposite of 7

B2 BASICS WITH INTEGRAL LEVERS

B2-5
BASIC SWITCHES

SINGLE BREAK, SNAP-ACTION, COMMERCIAL & MILITARY GRADES, SUBMINIATURE, TWO WIDTHS, INTEGRAL LEVERS

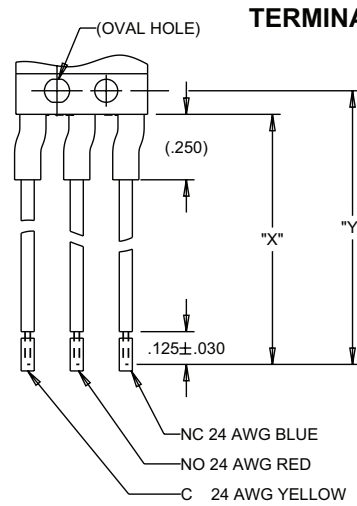
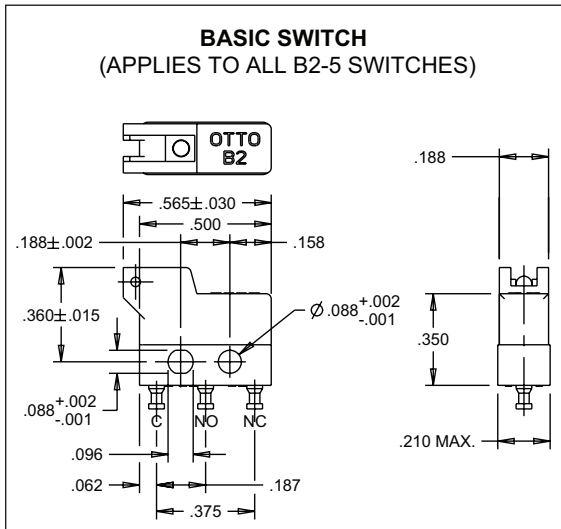

WIRE LENGTH FOR A, B, C, D & E

WIRE LENGTH CODE	DIM. "X"	DIM. "Y"
A	06.00±.38	06.09±.38
B	12.00±.50	12.09±.50
C	18.00±.50	18.09±.50
D	24.00±.50	24.09±.50
E	30.00±.75	30.09±.75

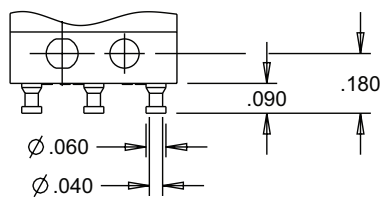

TERMINAL STYLE 1
SINGLE SOLDER TURRET

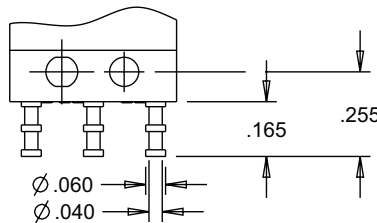

TERMINAL STYLE 2
DOUBLE SOLDER TURRET

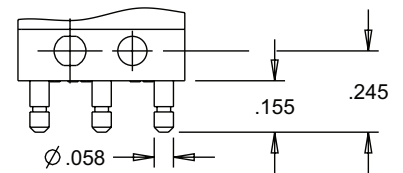

TERMINAL STYLE 3
QUICK CONNECT
MATES WITH AMP .058 INCH RECEPTACLES

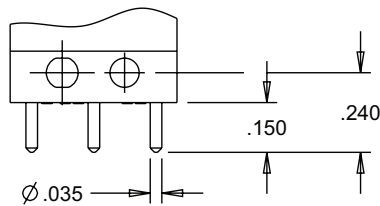

TERMINAL STYLE 4
PRINTED CIRCUIT PIN 0.150" LONG

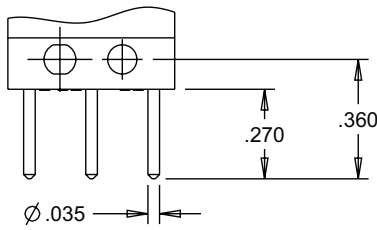

TERMINAL STYLE 5
PRINTED CIRCUIT PIN 0.270" LONG

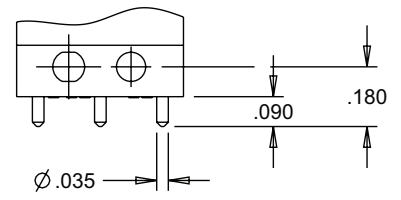

TERMINAL STYLE 6
PRINTED CIRCUIT PIN 0.090" LONG

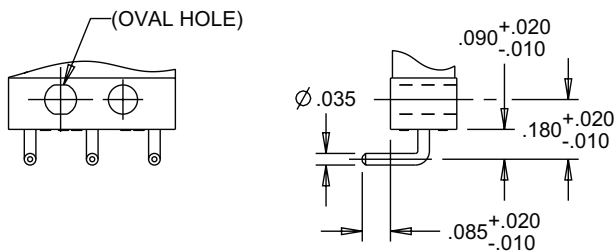

TERMINAL STYLE 7
RIGHT ANGLE PRINTED CIRCUIT PIN

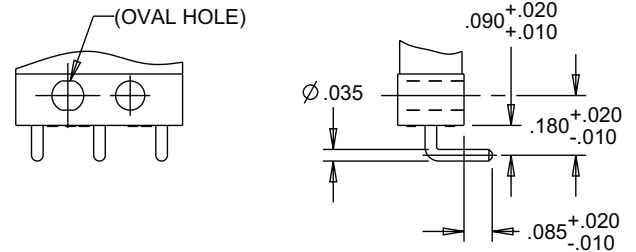

TERMINAL STYLE 9
RIGHT ANGLE, OPPOSITE OF 7

SINGLE BREAK, SNAP-ACTION, COMMERCIAL & MILITARY GRADES, SUBMINIATURE, TWO WIDTHS, INTEGRAL LEVERS

B2-5 LEVER STYLES

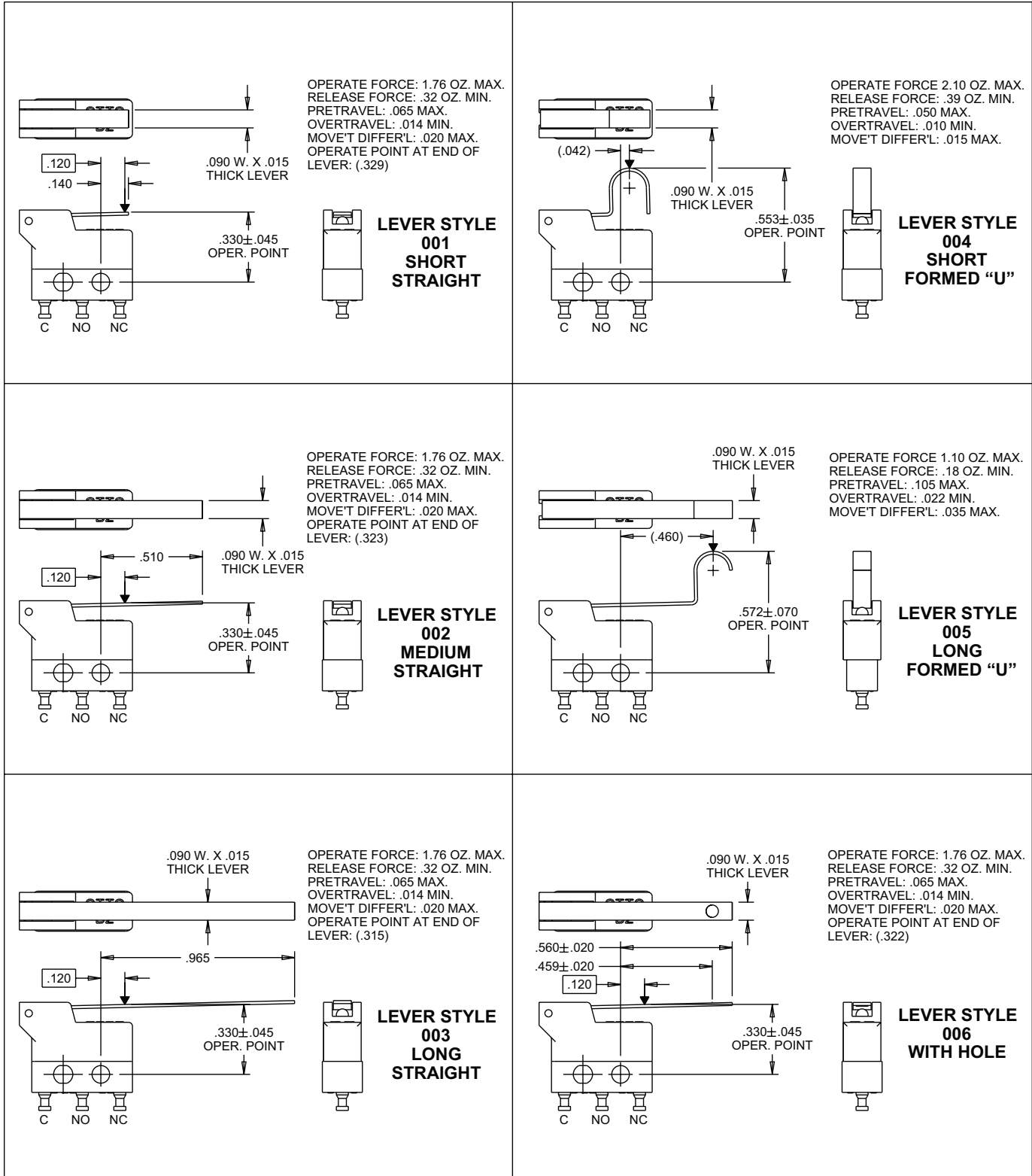

SINGLE BREAK, SNAP-ACTION, COMMERCIAL & MILITARY GRADES, SUBMINIATURE, TWO WIDTHS, INTEGRAL LEVERS

B2-5 LEVER STYLES

