

EP Series



A range of sturdy and light 19" enclosures. Designed to meet IEC 60 297 and DIN 41 494, they accept full-width 84E subracks and cases.

Heights from 2U up to 9U.
 Constructed entirely in 1 mm thick steel.
 Finished in grey graphite epoxy matt paint finished.
 Supplied with ABS plastic feet, tilt-feet in front, fixed feet in rear.
 Ventilation slots in base and rear panel.
 Side panels have recessed handles in ABS, ergonomically disposed for comfort and ease transport.

Basic unit includes: top and bases covers, two side panels, one rear panel, four feet (two tilt-up feet in frontal part), brackets, handles and mounting hardware.
 Supplied flat-pack.

Finish: upper and lower lid and side panels, epoxy painted in graphite grey colour.
 Handles injected in ABS, black colour similar to RAL 9004. Legs in ABS, dark grey finished similar to RAL 7016.

Optional:

- customized dimensions or finish.
- bespoke machining to customer requirements.
- optional castors.

Gamme de coffrets métalliques 19" d'une excellente résistance et un poids minime pour l'ensemble. Construits selon les normes IEC 60 297 (DIN 41494), ils permettent de loger des subracks et des coffrets normalisés de 84E.

Hauteurs de 2U à 9U.
 Fabriqués totalement en acier, épaisseur 1 mm.
 Finition, couleur gris graphite.
 Fournis avec des pieds en ABS injecté, parois frontales rabattables et postérieurs fixes.
 Ventilation dans les panneaux inférieur et postérieur.
 Poignées ergonomiques en ABS dans les parois latérales pour un transport commode et sûr.

L'unité inclut: Couvercle supérieur, couvercle inférieur, deux panneaux latéraux, un couvercle postérieur, quatre pieds (les deux frontaux rabattables), deux équerres, poignées et visserie.

Finitions: Couvercle, base et parois latérales en peinture époxy texturée mate, couleur gris graphite.
 Poignées en ABS, couleur noire similaire à RAL 9004. Pieds en ABS, couleur gris foncé similaire à RAL 7016.

En option:

- Autres mesures et finitions.
- Usinages selon les besoins.
- Roues en option.

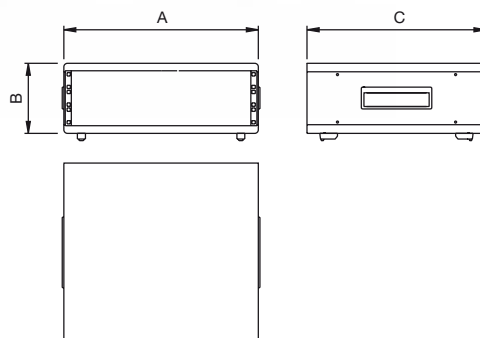

CODE	Description Description	A	B	C
32060233	Europac 2U F330	489	131.5	330
32060245	Europac 2U F450	489	131.5	450
32060333	Europac 3U F330	489	176	330
32060345	Europac 3U F450	489	176	450
32060633	Europac 6U F330	489	306	330
32060645	Europac 6U 450	489	306	450
32060945	Europac 9U 450	489	443	450

EP Series F330

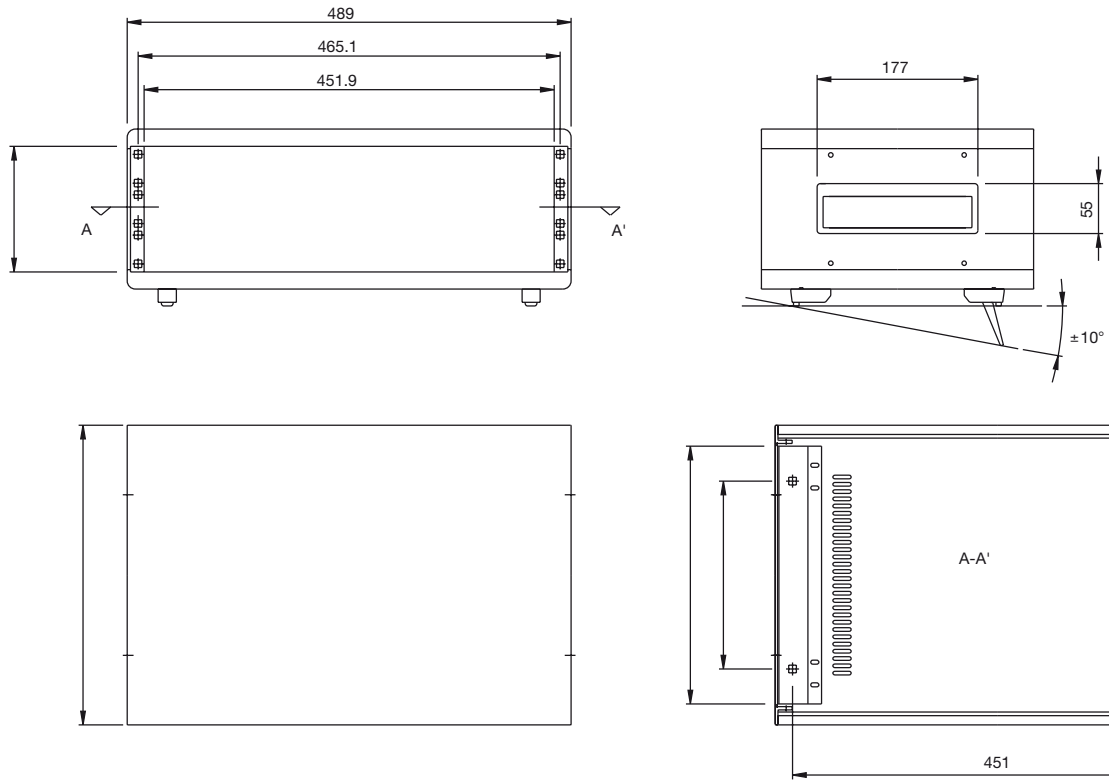

EP Series F450

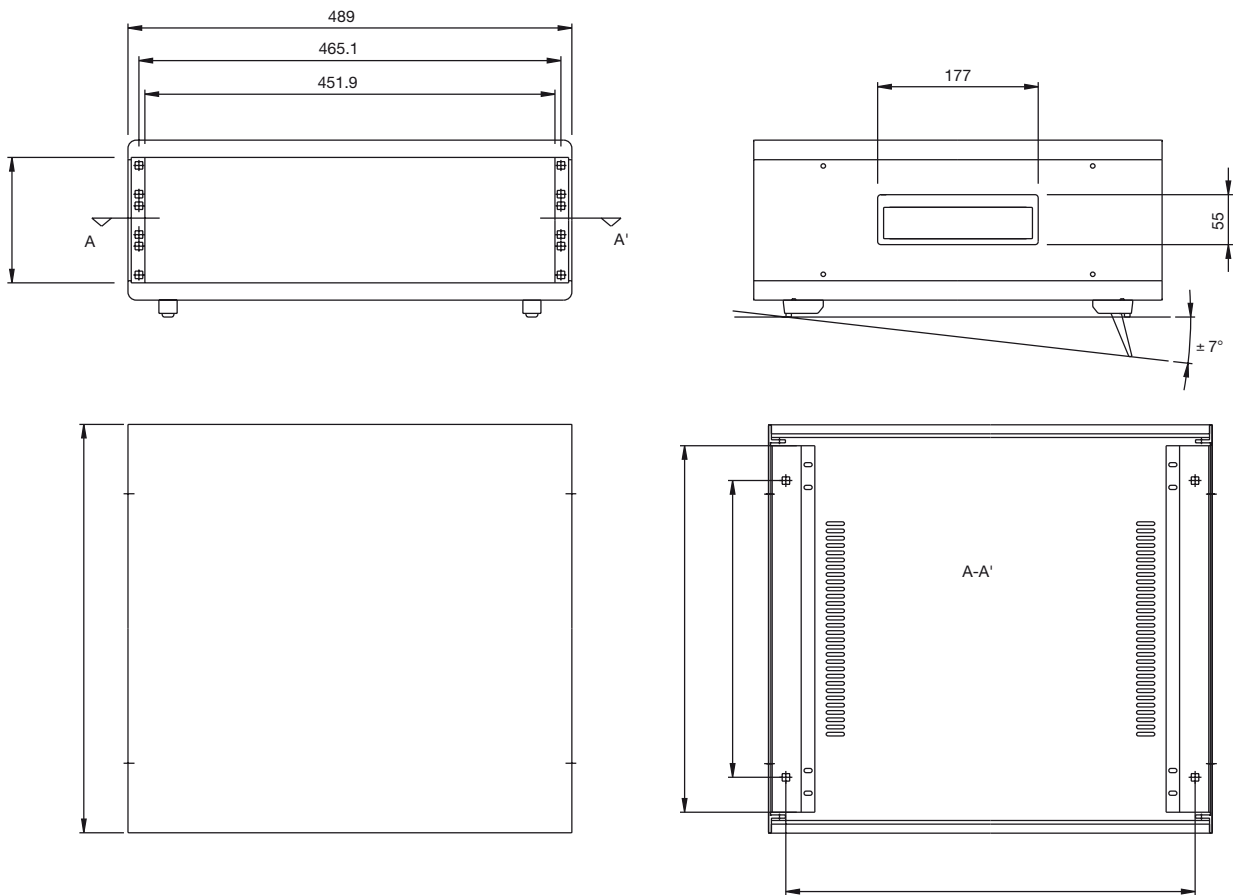

Accessories Accessoires

19" Front panel Panneau 19"

- Made of 3mm thick aluminium. Finish: silver anodised or grey graphite. Other dimensions on request.
- Fabriqu  en aluminium d' paisseur 3 mm. Finition anodis  argent ou peint gris graphite. Autres dimensions sur commande.

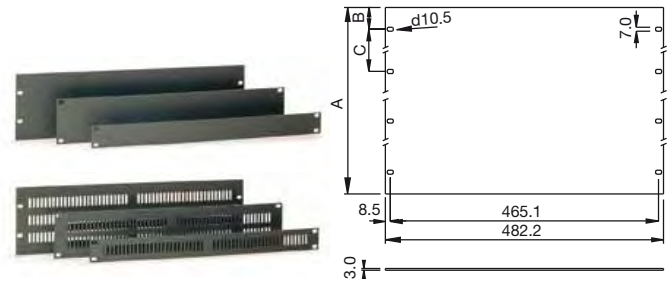

CODE	Description Description	Finish Finition		A	B	C
		Silver anodized Anodis� argent	Grey graphite painted Peint en gris graphite			
32155001	Front panel Panneau frontal 19" 1U	*		43.6	5.9	
32155002	Front panel Panneau frontal 19" 2U	*		88.1	5.9	
32155003	Front panel Panneau frontal 19" 3U	*		132.5	37.7	
32155004	Front panel Panneau frontal 19" 4U	*		177.0	37.7	
32155005	Front panel Panneau frontal 19" 5U	*		221.5	37.7	
32155006	Front panel Panneau frontal 19" 6U	*		265.9	37.7	
32155009	Front panel Panneau frontal 19" 9U	*		399.2	37.7	101.6
32155021	Front vented panel Panneau frontal ventil� 19" 1U	*		43.6	5.9	
32155022	Front vented panel Panneau frontal ventil� 19" 2U	*		88.1	5.9	
32155023	Front vented panel Panneau frontal ventil� 19" 3U	*		132.5	37.7	
32155024	Front vented panel Panneau frontal ventil� 19" 4U	*		177.0	37.7	
32155025	Front vented panel Panneau frontal ventil� 19" 5U	*		221.5	37.7	
32155026	Front vented panel Panneau frontal ventil� 19" 6U	*		265.9	37.7	
32155029	Front vented panel Panneau frontal ventil� 19" 9U	*		399.2	37.7	101.6
32155101	Front panel Panneau frontal 19" 1U		*	43.6	5.9	
32155102	Front panel Panneau frontal 19" 2U		*	88.1	5.9	
32155103	Front panel Panneau frontal 19" 3U		*	132.5	37.7	
32155104	Front panel Panneau frontal 19" 4U		*	177.0	37.7	
32155105	Front panel Panneau frontal 19" 5U		*	221.5	37.7	
32155106	Front panel Panneau frontal 19" 6U		*	265.9	37.7	
32155109	Front panel Panneau frontal 19" 9U		*	399.2	37.7	101.6
32155111	Front vented panel Panneau frontal ventil� 19" 1U		*	43.6	5.9	
32155112	Front vented panel Panneau frontal ventil� 19" 2U		*	88.1	5.9	
32155113	Front vented panel Panneau frontal ventil� 19" 3U		*	132.5	37.7	
32155114	Front vented panel Panneau frontal ventil� 19" 4U		*	177.0	37.7	
32155115	Front vented panel Panneau frontal ventil� 19" 5U		*	221.5	37.7	
32155116	Front vented panel Panneau frontal ventil� 19" 6U		*	265.9	37.7	
32155117	Front vented panel Panneau frontal ventil� 19" 9U		*	399.2	37.7	101.6

Chassis Ch ssis

- Easy mounting to the enclosure by four attachment points for M4 screws (not included).
- Made in 1 mm steel. Finish zinc coating.
- Maximum load recommended: 5 Kg.
- Packaging unit: 1 chassis.
- Montage facile sur le coffret par quatre points d'ancrage sur le rack au moyen de vis M4 (non incluses).
- Fabriqu  en acier d' paisseur 1 mm. Finition galvanis e.
- Charge maximale statique recommand e 5 kg.
- Unit d'emballage: 1 ch ssis.

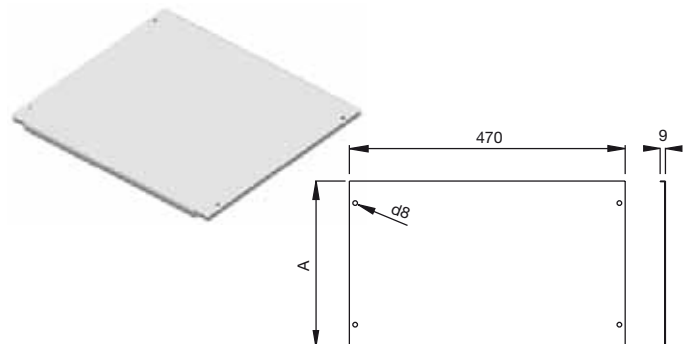

CODE	Description Description	A
32060033	Chassis depth Profondeur ch�ssis 330	282
32060045	Chassis depth Profondeur ch�ssis 450	402

Rear lid Panneau post rieur

- Standard ventilation slots. Made of 1 mm. thick steel. Colour grey graphite epoxy paint.
- Fentes de ventilation standard. Fabriqu  en plaque d'acier de 1 mm. Peint  poxy gris graphite.

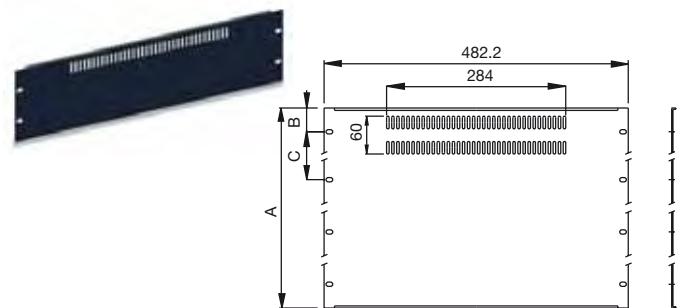

CODE	Description Description
32155052	Rear lid Panneau post�rieur 19" 3U
32155053	Rear lid Panneau post�rieur 19" 3U
32155054	Rear lid Panneau post�rieur 19" 4U
32155055	Rear lid Panneau post�rieur 19" 5U
32155056	Rear lid Panneau post�rieur 19" 6U
32155059	Rear lid Panneau post�rieur 19" 9U

19" Attachment set Set de fixation

- Attachment screw M6x12mm, philips-slotted head and zinc-coated, M6 cage nut, zinc-coated steel, and PA washer.
- Packaging unit: 20 sets.
- Vis de fixation M6x12mm, t te type philips combin e, galvanis e, avec rondelle PA et  crou encag  M6 d'acier galvanis .
- Unit d'emballage: 20 sets



CODE 30100114